

IN-FLOW^{CTA}

Industrial Mass Flow Meters and Controllers for Gases

> Introduction

Bronkhorst High-Tech B.V., the European market leader in thermal Mass Flow Meters/Controllers and Electronic Pressure Controllers, has many years of experience in designing and manufacturing precise and reliable measurement and control devices. With a wide range of instruments and offering innovative solutions for many different applications in a variety of different markets, Bronkhorst High-Tech is dedicated to customer satisfaction, quality and sustainability.

> IN-FLOW^{CTA} series for industrial applications

The Mass Flow Meters and Controllers of the IN-FLOW^{CTA} series are of rugged design (IP65) for use in pilot and production plants in industrial environments. The instruments operate on the principle of direct thermal mass flow measurement (no by-pass) and have no moving parts and no obstructions to the flow path. These features make IN-FLOW^{CTA} Mass Flow Meters ideal for low pressure drop applications and for the use on wet or dirty gases. Another advantage of using this type of sensor is that the instruments measure direct mass flow, without the need of temperature and pressure correction. Mass Flow Meters can be supplied in ranges starting from 10...200 ml_n/min up to 50...5000 l_n/min Air-equivalent. Mass Flow Control loops can be offered, up to 4...200 l_n/min Air-equivalent as flow meter with integrated control valve and up to 5000 l_n/min with separate control valve.

> State of the art digital design

The IN-FLOW^{CTA} Mass Flow Meters and Controllers are equipped with a digital pc-board, offering excellent performance and many features, at an affordable price. The main digital pc-board on the instrument contains all of the general functions needed for measurement and control. It has analog I/O-signals and also an RS232 connection as a standard feature. In addition to this there is the possibility of integrating an interface board with DeviceNet™, Profibus-DP®, Modbus-RTU or FLOW-BUS protocol.



> General IN-FLOW^{CTA} features

- ◆ Virtually pressure and temperature independent
- ◆ Low pressure drop
- ◆ Weatherproof IP65 housing
- ◆ Optional: ATEX approval Cat.3, Zone 2
- ◆ Virtually insensitive to moisture or particulates
- ◆ Outstanding price/performance ratio
- ◆ Compliant with RoHS directives

> Digital features

- ◆ Profibus-DP®, DeviceNet™, Modbus-RTU or FLOW-BUS slave
- ◆ RS232 interface
- ◆ Alarm and counter functions
- ◆ Control characteristics user configurable

> Technical specifications

Performance	
Accuracy (incl. linearity) (based on actual calibration)	: ± 1% FS plus ± 1% RD
Repeatability	: < 0,2% FS typical
Turndown	: 1 : 50 or 1 : 100 (see flow range table)
Operating pressure	: 0...10 bar(g)
Pressure sensitivity	: 0,3% RD/bar typical at Air
Operating temperature	: 0...50°C;
Temperature sensitivity	: zero: < 0,1% FS/°C; span: < 0,2% RD/°C
Leak integrity (outboard)	: tested < 2 x 10 ⁻⁹ mbar l/s He
Attitude sensitivity	: max. error at 90° off horizontal 0,2% at 1 bar, typical N ₂
Sensitivity to upstream piping configuration	: virtually insensitive
Response time (sensor, t63%)	: T10/T11: 0,3 seconds; other models: 0,9 seconds
Settling time (controller)	: approx. 2 seconds
Warm-up time	: 30 min. for optimum accuracy 2 min for accuracy ± 2% FS
Mechanical parts	
Material (wetted parts)	: SS316; other on request
Process connections	: BSPP female thread: T10/T20/T11/T21: 1/8" T12/T22: 1/4" T13/T23/T14: 1/2" T15: 1"
Seals	: standard: Viton; options: EPDM, FFKM (Kalrez)
Ingress protection (housing)	: IP65
Electrical properties	
Power supply	: + 15...24 Vdc
Power consumption	: meter: max. 125 mA; controller: max. 375 mA; add 50 mA for Profibus, if applicable
Analog output/command	: 0...5 (10) Vdc or 0 (4)...20 mA (sourcing output)
Digital communication	: standard: RS-232 options: Profibus-DP®, DeviceNet™, Modbus-RTU, FLOW-BUS
Electrical connection	
Analog/RS232	: 8-pin DIN male
Profibus-DP®	: bus: 5-pin M12 female; power: 8-DIN male
DeviceNet™	: 5-pin M12 male
Modbus-RTU/FLOW-BUS	: 5-pin M12 male
<i>Technical specifications subject to change without notice</i>	

> Warranty

All instruments and accessories are warranted for a period of 3 years from order date.

> Models and flow ranges (based on Air)

Mass Flow Meters (MFM)		
Model	Minimum	Maximum
T10	0,01...0,2 l _v /min	0,02...2 l _v /min
T11	0,02...1 l _v /min	0,05...5 l _v /min
T12	0,1...5 l _v /min	0,5...50 l _v /min
T13	0,4...20 l _v /min	2...200 l _v /min
T14	2...100 l _v /min	10...1000 l _v /min
T15	10...500 l _v /min	50...5000 l _v /min
Mass Flow Controllers (MFC)		
Model	Minimum	Maximum
T20 ¹⁾	0,01...0,2 l _v /min	0,04...2 l _v /min
T21 ¹⁾	0,02...1 l _v /min	0,1...5 l _v /min
T22 ¹⁾	0,1...5 l _v /min	1...50 l _v /min
T23 ²⁾	0,4...20 l _v /min	4...200 l _v /min
¹⁾ K _v -max = 6,6 x 10 ⁻² ²⁾ K _v -max = 0,35		

The MFCs listed above are equipped with integrated control valves. For higher flowrates Bronkhorst High-Tech offers combinations of Mass Flow Meters with separate control valves. Typical combinations:

T13 + F-002AI, K_v-max = 0,4
 T13 + F-004AI, K_v-max = 0,3
 T14 + F-003AI, K_v-max = 1,5
 T14 + F-004BI, K_v-max = 1
 T15 + F-003BI, K_v-max = 6

> Conversion factor table

For conversion to Air at 1013 mbar and 0°C you may use the following table for model selection:

Gas	Cf (T10, T11, T20, T21)	Cf (other models)	Gas	Cf (T10, T11, T20, T21)	Cf (other models)
Air	1,00	1,00	CO ₂	0,86	1,13
Ar	1,50	2,02	HCl	1,12	1,53
CH ₄	0,77	0,61	N ₂	1,00	1,00
C ₂ H ₂	0,66	0,68	NH ₃	0,82	0,74
C ₂ H ₄	0,70	0,75	NO	1,00	1,01
C ₂ H ₆	0,58	0,62	N ₂ O	0,83	1,08
C ₃ H ₈	0,43	0,51	O ₂	0,99	0,97
C ₄ H ₁₀	0,32	0,41	Xe	1,96	6,09
CO	1,01	1,04	Other gases on request		

Best accuracy is achieved by calibrating IN-FLOW^{CTA} instruments under actual process conditions. The conversion factor introduces an additional error in absolute accuracy in the order of:

$$Cf \geq 1 : 2xCf \text{ in } \% \text{ FS}$$

$$Cf \leq 1 : 2/Cf \text{ in } \% \text{ FS}$$

> Dimensions (mm)

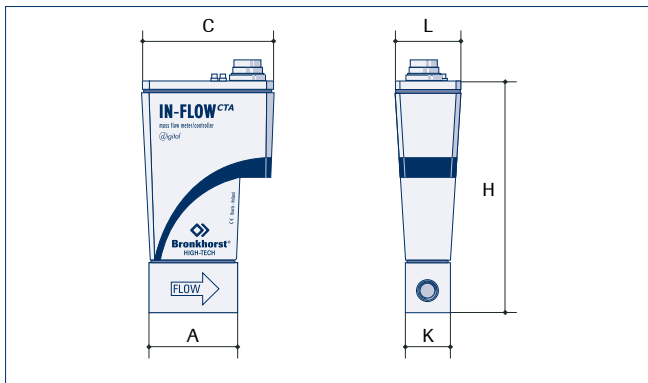

Mass Flow Meter

Model	A	C	H	K	L
T10/T11	47	74	129	25	36
T12	90	74	125	30	36
T13	90	74	135	30	36
T14	115	74	150	40	36
T15	155	74	180	75	36

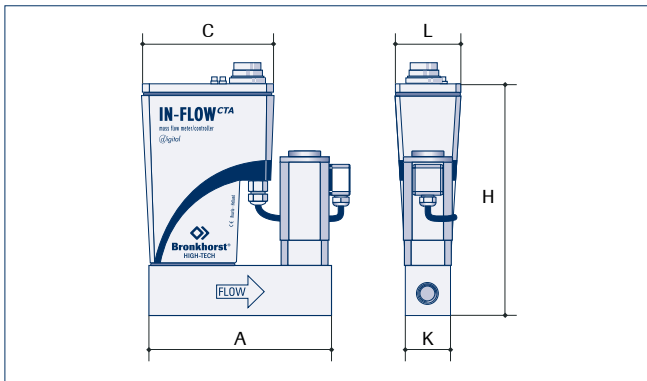

Mass Flow Controller

Model	A	C	H	K	L
T20/T21	100	74	129	25	36
T22	120	74	125	30	36
T23	135	74	135	34	36

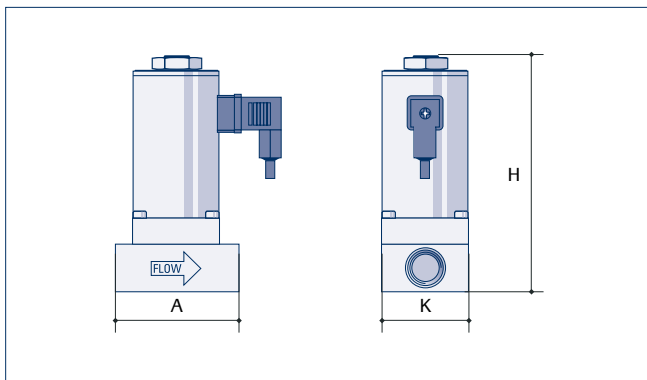

Control Valves

Model	A	H	K
F-002AI	78	116	59
F-004AI	64	122	45
F-003AI	97	130	74
F-004BI	85	174	65
F-003BI	114	147	89

> Accessories

For the IN-FLOW^{CTA} Mass Flow Meters and Controllers we offer the following accessories:

Adapter sets (in- and outlet, OD compression type)

For models	Inch sizes	Metric sizes
T10/T20	1/8" / 1/4"	6 mm
T11/T21	1/4"	6 mm
T12/T22	1/4" / 1/2"	6 mm / 12 mm
T13/T23	1/2"	12 mm
T14	1/2" / 3/4"	12 mm / 20 mm
T15	1"	25 mm

Power supply and electrical connection

- ◆ Plug-in Power
Supply 110-240 Vac, c/w cable 2 m
- ◆ Split cable
Power/Signal, 30 cm
- ◆ Interconnecting cable, RJ-45 – Loose end, 3 m
- ◆ RS-232 cable, RJ-45 – 9-pin Sub-D, 3 m

BRIGHT Series, IP65 Local Readout/Control Module

Mounted directly on MFM/MFC or on wall, panel or pipework



BRIGHT module



IN-FLOW^{CTA} model T15 Mass Flow Meter for high flow rates

> Fields of application

The IN-FLOW^{CTA} series find application in a wide variety of applications in the following markets (typically):

- ◆ Gas consumption monitoring for internal accounting
- ◆ Process gas measurement or control in food, pharmaceutical and (petro-) chemical industries, in fermentation installations and in fuel cell technology
- ◆ Environmental technology (air sampling)
- ◆ Methane production in anaerobic digestors
- ◆ Surface treatment (coating, hardening)
- ◆ Test benches

Some typical examples of applications are:

> Burner Control

Burner control using Mass Flow Controllers brings many advantages compared to conventional systems, where flow is adjusted through needle valves. When burner orifices get clogged or when gas supply pressure varies, an MFC will automatically adapt to the changed conditions. For the control of relatively large flows with low differential pressure, which is typical for natural gas or CH₄, Bronkhorst High-Tech offers mass flow meters with separate pressure compensated bellows valves.

> Measurement of leak or throughput

Mass Flow Meters are often installed in quality control test benches to determine, for example, the leak through valves or engine blocks. In similar systems the gas throughput is measured of filter, membranes, catalists, etc. The results of the measurement can be indicated on a display as a readout value or as a minimum or maximum alarm.

> Gas consumption measurement

When mass flow meters are installed at locations with different cost centres (laboratories, hospitals, etc.) it will be clear which users are responsible for the gas consumption. This enables a fair internal accounting and will often lead to a reduced expenditure for the organisation.

> Air supply in food processing

In many systems in the food industry you will find Bronkhorst's mass flow meters and controllers being used for air supply in ratio to a bulk mass stream of half-finished product. Some typical examples are: icecream and other dairy products, dough for bakery products and candy or chocolate foam.

> Compressed air flow measurement

IN-FLOW^{CTA} Mass Flow Meters are ideally suited for the monitoring of compressed air systems. Due to their construction, the instruments are insensitive to any moisture, oil or particulates that may be carried through the compressed air network. Furthermore, the mass flow meters are virtually independent from variations in both pressure and temperature. Typical applications would include performance testing, leak detection, maintenance management and the measurement of compressed air consumption. For point of use measurement we recommend our BRIGHT display module, which can indicate both actual and totalized air flow.

> Bronkhorst FlowWare, free software tools

Bronkhorst High-Tech offers the following software support for installation and operation by personal computer:

- *FlowDDE*: Software tool to interface between digital instruments and windows software.
- *FlowPlot*: Software tool for monitoring and optimizing digital instruments parameters.

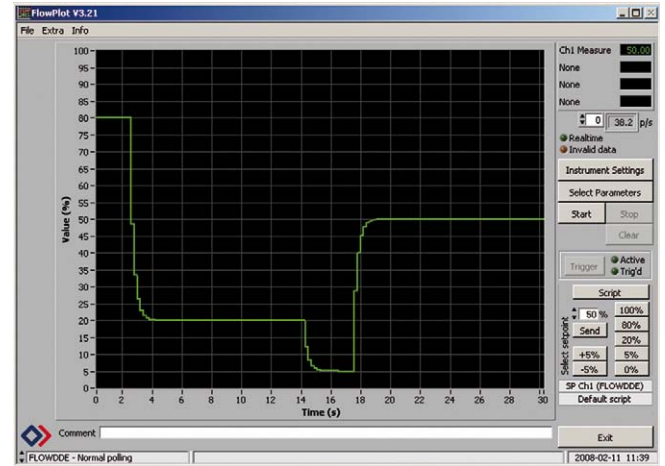

- *FlowView*: Software tool to operate Bronkhorst digital instruments.

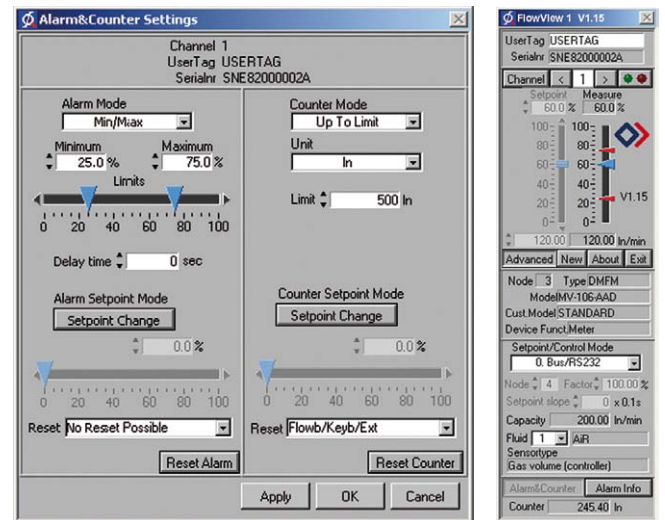

These software tools are freeware for users of our IN-FLOW^{CTA} series and other digital Bronkhorst instruments.

Thru-flow measurement using CTA flow sensor

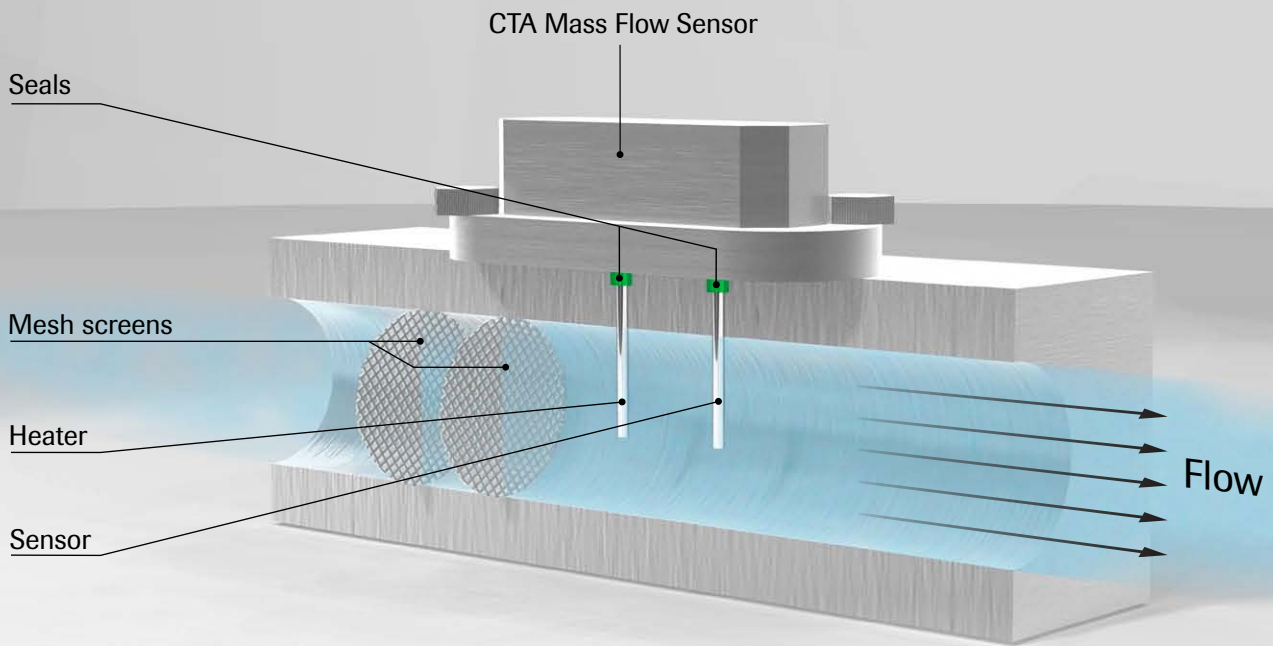

> CTA* Measuring principle

Basically the IN-FLOW^{CTA} Mass Flow Meter consists of a straight tube. Two stainless steel probes protrude inside the flow channel; a heater probe and a temperature sensor probe. A constant temperature (ΔT) is created between the two probes and the energy required to maintain this ΔT is proportional to the mass flow rate. Based on this concept, mass flow can be measured with low pressure drop, mainly caused by the gas fittings and the mesh screens which are incorporated for flow conditioning. Compared to traditional thermal MFMs and MFCs with bypass, the direct measuring IN-FLOW^{CTA} is less sensitive to humidity and contamination.

* CTA means Constant Temperature Anemometry

> Pressure drop for Mass Flow Meters [for Air at 20°C / 1013 mbar(a)]

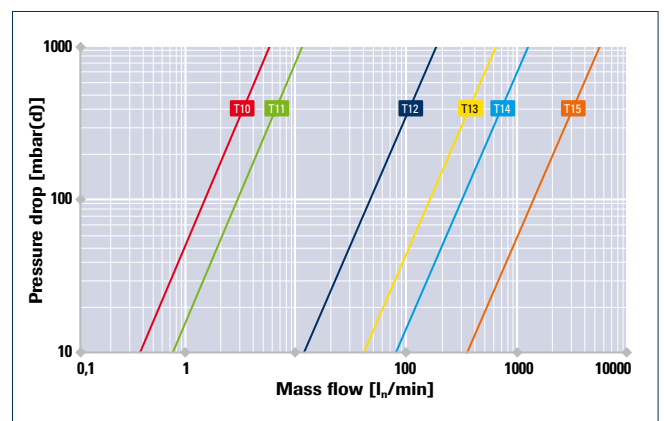

> Model number identification

T N N - N N N - NN - A

Base

1	Meter
2	Controller

Capacity (based on air)

0	ultra low flow (UF)	up to 2 l _v /min
1	small flow (SF)	up to 5 l _v /min
2	low flow (LF)	up to 50 l _v /min
3	medium flow (MF)	up to 200 l _v /min
4	high flow (HF)	up to 1000 l _v /min
5	very high flow (VF)	up to 5000 l _v /min

Communication (I/O)

A	RS232 + analog (n/c)
B	RS232 + analog (n/o)
D	RS232 + DeviceNet™ (n/c)
E	RS232 + DeviceNet™ (n/o)
M	RS232 + Modbus-RTU (n/c)
N	RS232 + Modbus-RTU (n/o)
P	RS232 + Profibus-DP® (n/c)
Q	RS232 + Profibus-DP® (n/o)
R	RS232 + FLOW-BUS (n/c control)
S	RS232 + FLOW-BUS (n/o control)

Analog output

A	0...5 Vdc
B	0...10 Vdc
F	0...20 mA sourcing
G	4...20 mA sourcing

Supply voltage

D	+15...24 Vdc
---	--------------

Internal seals

V	Viton (factory standard)
E	EPDM
K	Kalrez (FFKM)

Connections (in/out)

		UF	SF	LF	MF	HF	VF
0	None (factory standard)	•	•	•	•	•	•
1	1/8" OD compression type	•					
2	1/4" OD compression type	•	•	•			
3	6 mm OD compression type	•	•	•			
4	12 mm OD compression type			•	•	•	
5	1/2" OD compression type			•	•	•	
6	20 mm OD compression type				•	•	
8	1/4" Face seal male	•	•	•			
9	Other: 3/4" OD compr. type				•	•	
	1" OD compr. type					•	•
	25 mm OD compr. type					•	•



IN-FLOW^{CTA} model T13 Mass Flow Meter with close coupled Control Valve F-002B1



IN-FLOW^{CTA} model T21 Mass Flow Controller for small flow rates



Nijverheidsstraat 1a, NL-7261 AK Ruurlo The Netherlands

T +31(0)573 45 88 00 F +31(0)573 45 88 08 I www.bronkhorst.com E info@bronkhorst.com

