

Food and Beverage – Ice Cream Aeration

Application note A001H-FB04A01-0111A



Ice cream is made by freezing and simultaneously blending air into a liquid mixture which contains fat, sugar, milk solids, an emulsifying agent, flavouring and sometimes colouring agents. For ice cream production the aeration process is crucial.

The air content in ice cream (often called overrun) affects the taste, texture and appearance of the finished product. Higher aeration will produce a tastier and smoother ice cream. Thus, for attaining an optimal structure of the ice cream, production machines must possess an accurate air flow controller that is able to deliver the amount of air necessary to maintain the ratio between cream and air constant, as a function of the cream flow.



Continuous aeration mixer

- ◆ **Ice cream**
- ◆ Whipped cream
- ◆ Marshmallow

Application requirements

The air mass flow controller must be assembled as a slave of the cream flow controller, therefore, some continuous mixers manufacturers require instruments having analogue, while others require bus (digital) communication features (both available).

Combined with the instrument's high performance, this setup will enable a continuous and stable air flow against the required backpressure of the mixer. Due to the existing regulation, equipment users also require qualified filter systems.

Important topics

- ◆ Constant cream aeration
- ◆ Precise dosing
- ◆ Reproducibility
- ◆ Stable Control

Process solution

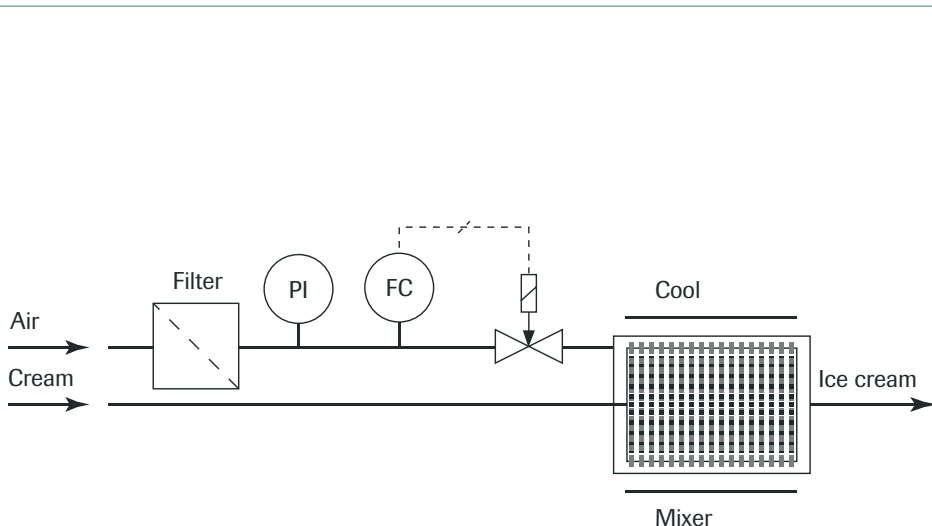

A schematic technical diagram showing our product included in the customer's process

Whipping ice cream into shape

To guarantee the right consistency and structure which ensure a full flavoured ice cream, the ice cream must contain the correct proportion and composition of air bubbles. Hence continuous aeration mixer manufacturers use a mass flow controller to dose an exact amount of air into the cooled mixer. Such mass flow controller (slave) will ensure a continuous air delivery, proportional to the cream flow (master). The mass flow controller must be capable of maintaining its performance regardless of any possible back pressure variation. Occasionally, a check valve is mounted at the mass flow controller's downstream. If inlet pressure drops, such valve will avoid ice back stream into the instrument. A pressure meter is also used with the purpose of monitoring the inlet pressure. ■

The SEM picture shows the ice cream microstructure. Air bubbles are a critical ingredient. Experts claim its optimal size, distribution and quantity are one of the secrets for having a creamy texture recipe. Hence, according to meet such demands, Bronkhorst High-Tech has provided efficient solutions for enhancing continuous aeration processes.

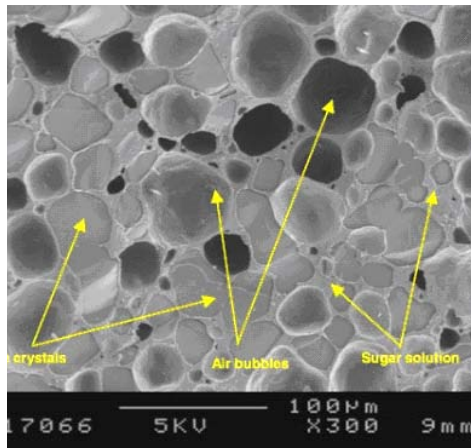

SEM picture of ice cream microstructure



Ice cream mixer.

Recommended Products



EL-FLOW

Mass Flow Meters and Controllers for gas applications have a housing designed for laboratory and clean processing conditions. The instruments are truly unique in their capability to measure and control flow ranges between 0...1 ml_n/min and 0...1670 l_n/min with pressure rating between vacuum and 400 bar – all in one range of instruments.

- ◆ Fast response, excellent repeatability
- ◆ High accuracy
- ◆ Virtually pressure and temperature independent
- ◆ Maintainability and stability
- ◆ Available with analog and digital in-/output.
- ◆ Standard RS232 output
- ◆ optional field bus interface: DeviceNet™ / Profibus-DP® / EtherCat® / Modbus / FLOW-BUS



EL-PRESS

The EL-PRESS series electronic Pressure Meter has a well-proven compact thru-flow design and is available in pressure ranges from 2...100 mbar up to 8...400 bar.

- ◆ high accuracy and repeatability
- ◆ high pressure capability up to 400 bar
- ◆ suitable for gases and liquids
- ◆ optional metal sealed and down-ported constructions
- ◆ standard analog 0...5(10) V / 0(4)...20 mA and digital RS232 communication
- ◆ optional field bus interface: DeviceNet™ / Profibus-DP® / EtherCat® / Modbus / FLOW-BUS



IN-FLOW and IN-PRESS

IN-FLOW Series Mass Flow Meters/Controllers and the IN-PRESS series, digital Electronic Pressure Transducers (EPT's)/Controllers (EPC's) are instruments of modular construction with a 'industrial style' IP65 pc-board housing. Control valves can either be integrally or separately mounted,

- ◆ flow ranges IN-FLOW from 0,2...10 ml_n/min up to 220...11000 m³_n/h
- ◆ pressure ranges IN-PRESS from 0-100 mbar up to 0-400 bar
- ◆ Rugged, weatherproof housing (IP65, dust and waterproof)
- ◆ Analog or digital communication (RS232 or fieldbus interface)



mini CORI-FLOW M14

mini CORI-FLOW series, compact Coriolis Mass Flow Meter / Controller for liquids and gases. Both analog and digital output. Housing according to IP65 classification. World's smallest Coriolis Mass Flow Controller! Flow ranges from 0-20 g/h up to 0-30 kg/h. Production and sales by Bronkhorst Cori-Tech BV

- ◆ accuracy: 0.2% reading +/- zero stability
- ◆ SS316L wetted parts, all metal
- ◆ no moving parts
- ◆ temperature: 0...70 °C
- ◆ alarm and totalizer facilities
- ◆ fast response (up to 50 msec.)
- ◆ easily re-rangeable for different flow rates
- ◆ power: +15...24Vdc ; pressure: up to 200 bara

Contact information



T +31(0)573 45 88 00 F +31(0)573 45 88 08
I www.bronkhorst.com E info@bronkhorst.com

Ice Cream Aeration A001H-FB04A01-0111A

FB : Food and Beverage
04 : Food processing
A01 : Aeration

